

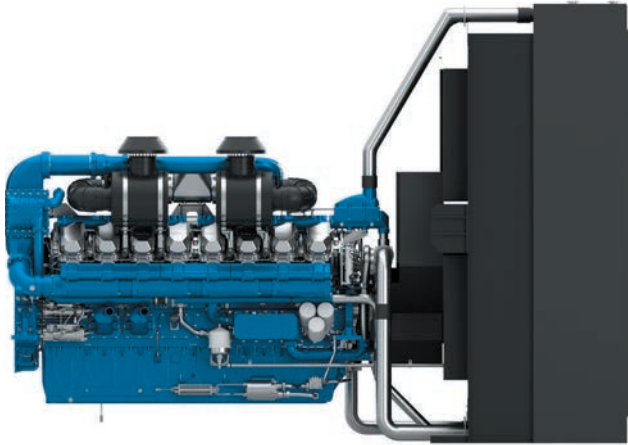

16M33

PowerKit ESP/PRP Diesel Engine



Bore & Stroke (mm)	150 x 185
Displacement (L)	52.3
N° of Cylinders	16
Cylinders Arrangement	At Vee
Fuel System	High Pressure Common Rail
Governor (Gov.)	ECU
Aspiration (Asp.)	T/A - W*

Customer benefits

Warranty terms - 2 yrs unlimited hours PRP, 4 yrs / 800 ESP
 50°C Cooling package standard with low derating
 Extended MTBO

Engine	Speed	Gross Engine Output		Typical Generator Output			
		PRP	ESP	PRP		ESP	
	RPM	kWm	kWm	kWe	kVA	kWe	kVA
16M33G1700/5	1500	1390	1530	1200	1500	1360	1700
16M33G1900/5	1500	1530	1680	1400	1750	1520	1900
16M33G2000/5	1500	1680	1800	1500	1875	1650	2050
16M33G2250/5 [^]	1500	1800	1980	1650	2050	1800	2250
16M33G1400/6	1800	1440	1580	1275	1594	1400	1750
16M33G1500/6	1800	1530	1680	1365	1706	1500	1875
16M33G1650/6	1800	1625	1785	1500	1875	1650	2063
16M33G1750/6 [^]	1800	1750	1920	1590	1988	1750	2188

[^] These engines are designed for emergency standby power (ESP) applications only. The indicated PRP Power is for reference only.

Standard equipment

Engine and block	<p>Cast iron cylinder block with inspection door per cylinder</p> <p>Cast iron cylinder liners, wet type and replaceable valves guides and seats</p> <p>Separate cast iron cylinder heads with 4 valves</p> <p>Hardened steel forged crankshaft with induction hardened journals, crankpins and radius</p> <p>Lube oil cooled light alloy pistons with high performance piston rings</p>
Cooling system	<p>Radiator and hoses supplied separately</p> <p>Two separate circuits</p> <p>High temperature circuit equipped with thermostatically-controlled system with two gear driven coolant pumps</p> <p>Low temperature circuit equipped with belt driven coolant pump</p>
Lubrication system	<p>Full flow screw able oil filters</p> <p>Lube oil purifier with replaceable cartridge</p> <p>Water cooled lube oil cooler</p>
Fuel system	<p>High pressure common rail system with one high pressure pump gear driven in the V angle of cylinder block</p> <p>Two rails mounted on the sides of the engine, double wall, under inlet manifold</p> <p>Duplex fine filter and water separation filter assembly with transparent cup for better efficiency</p> <p>Electric fuel priming pump integrated in the filters support</p>
Air intake and exhaust system	<p>The 2 compressors are feeding a single water-air intercooler, mounted over the flywheel housing, with vertical flow</p> <p>Special rear mounted air filter with restriction indicator</p> <p>Exhaust manifold and turbocharger shield for heat isolating</p>
Electrical system	<p>2 x 24V DC electric starter motors and n° 1 battery charging alternator</p> <p>Low oil pressure & high water temperature sensors</p>
Flywheel and housing	<p>SAE 0 flywheel housing and 18" flywheel</p>

Dimensions and dry weight (mm/kg)

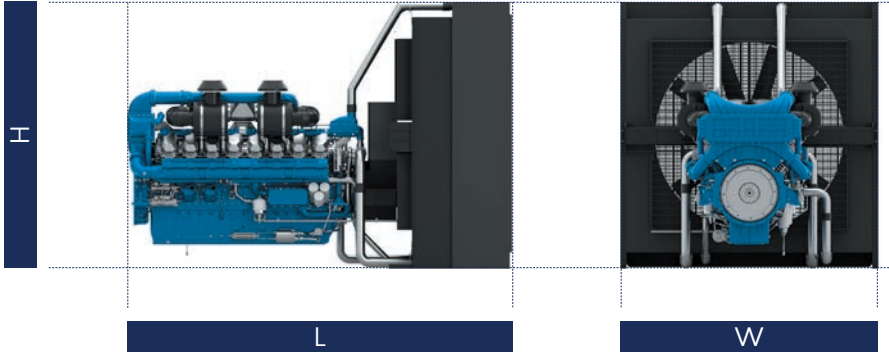

Diesel Engine	Speed	Dimensions and dry weights including radiator			
		L	W	H	Weight
	RPM	mm	mm	mm	Kg.
16M33G1700/5	1500	3678	2237	2682	6400
16M33G1900/5	1500	3678	2237	2682	6400
16M33G2000/5	1500	3678	2237	2682	6400
16M33G2250/5 [^]	1500	4116	2756	2870	6845
16M33G1400/6	1800	3678	2237	2682	6400
16M33G1500/6	1800	3678	2237	2682	6400
16M33G1650/6	1800	3678	2237	2682	6400
16M33G1750/6 [^]	1800	3678	2237	2682	6400

Ratings definitions

Emergency Standby Power (ESP)

Emergency Standby Power is the maximum power available for a varying load for the duration of a main power network failure. The average load factor over 24 hours of operation should not exceed 70% of the engine's ESP power rating. Typical operational hours of the engine is 200 hours per year, with a maximum usage of 500 hours per year. This includes an annual maximum of 25 hours per year at the ESP power rating. No overload capability is allowed. The engine is not to be used for sustained utility paralleling applications.

Unlimited Prime Rated Power (PRP)

Prime Power is the maximum power available for unlimited hours of usage in a variable load application. The average load factor should not exceed 70% of the engine's PRP power rating during any 24 hour period. An overload capability of 10% is available, however, this is limited to 1 hour within every 12 hour period.

- 1) All ratings are based on operating conditions under ISO 8528-1, ISO 3046, DIN6271. Performance tolerance of $\pm 5\%$.
- 2) Test conditions : 100 kPa, 25°C air inlet temperature, relative humidity of 30%, with fuel density 0.84 kg/L. Derating may be required for conditions outside these; please contact the factory for details.
- 3) Power output curves are based on the engine operating with fuel system, water pump and lubricating oil pump; not included are battery charging alternator, fan and optional equipment.