

Generating Set Range - Specifications

2, 3 or 4 cylinders with high inertia flywheel for smooth running at low rpm.

Heater plugs for cold starting below 5°C, fuel filter, **MECHANICAL** fuel lift pump, **MECHANICAL** fuel injection pump and **MECHANICAL** engine governing* ensures steadfast performance regardless of ambient conditions.

QUIET GEAR DRIVEN CAMSHAFT for maximum engine reliability and reduced servicing, as no timing chains or toothed belts have to be replaced.

The generating set seating in the vessel should be level in all planes so it can be bolted down without stress or distortion. Subject to criteria, Kubota based engines can accommodate angles of 15° when pitching and 25° when heeling.

All BetaSet-BetaGen models are 12 volt electric start as standard, models up to the BetaSet-BetaGen 21 are equipped with a 45 amp battery charging alternator, the BetaSet-BetaGen 26 though to the BetaSet-BetaGen 49 are equipped with a 70 amp insulated return battery charging alternator. Optional 24 volt electric start is available for selected models.

The engine and generator alternator are close coupled together and mounted on steel feet with marine failsafe anti-vibration mountings ensuring isolation. Base frames are an optional extra for all BetaSet models.

Available as **HEAT EXCHANGER, KEEL** or **RADIATOR COOLED**, all BetaSet-BetaGen models are naturally aspirated except the BetaSet-BetaGen 40T & 49T which are turbocharged.

*The BetaSet-BetaGen 14, 21, 49 & 49T are electronically governed.

Images Are For Illustration Purposes & Not Necessarily Representative.

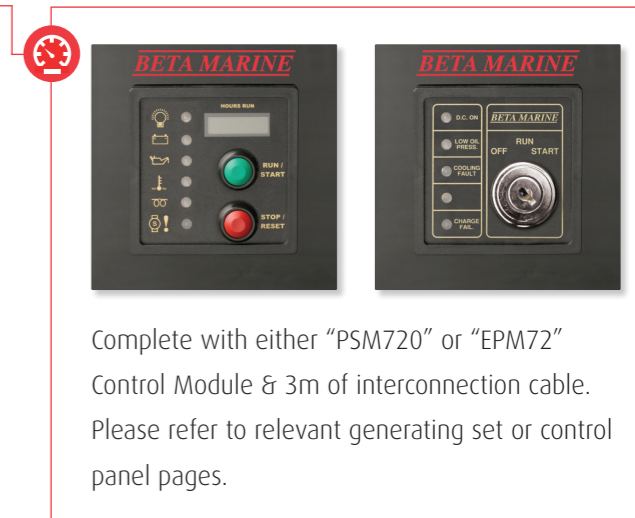
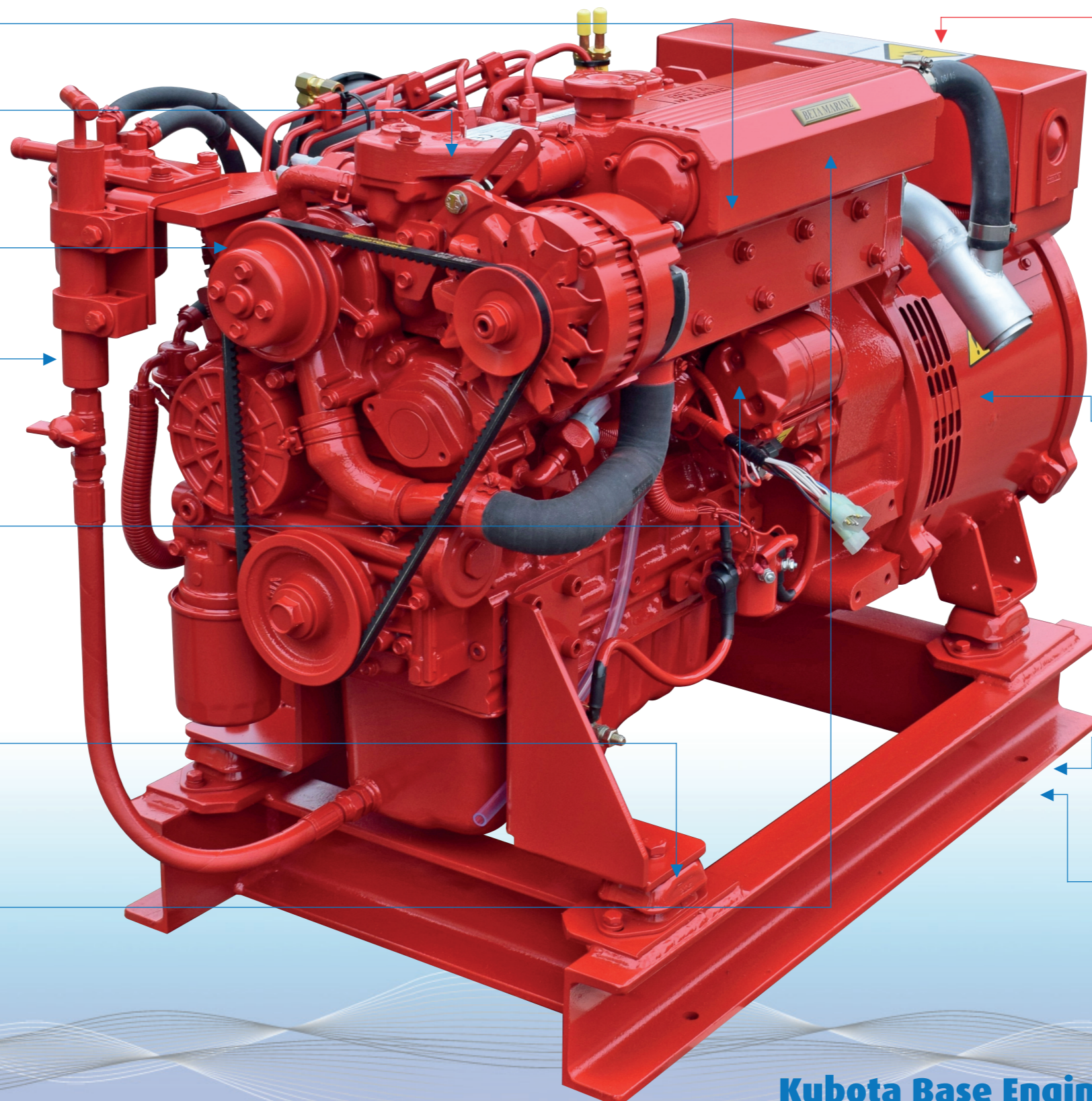

Complete with either "PSM720" or "EPM72" Control Module & 3m of interconnection cable. Please refer to relevant generating set or control panel pages.

The marine rated generating set alternator operates at 0.8pf, with either 50 Hz or 60 Hz frequency and has a ventilated drip proof enclosure with IP 22 protection & single bearing construction. The generator is self-regulating, self-excited and is complete with terminal box and automatic voltage regulator. Suitable for operation in engine room temperatures of up to 45°C. Standard 50 Hz voltage is 230v single phase, 400v 3 phase, or standard 60 Hz is 120v single phase, 208v 3 phase, other voltages are available upon request.

Kubota three vortex combustion (E-TVCS) with indirect injection for quiet running, low emissions and excellent fuel consumption – All BetaSet-BetaGen variants except the BetaSet-BetaGen 40T & 49T.

Kubota centre direct injection (E-CDIS) for quiet running, low emissions and excellent fuel consumption – BetaSet-BetaGen 40T & 49T.

Kubota Base Engine

BetaSet-BetaGen 22/2

Available With Heat Exchanger, Keel Or Radiator Cooling

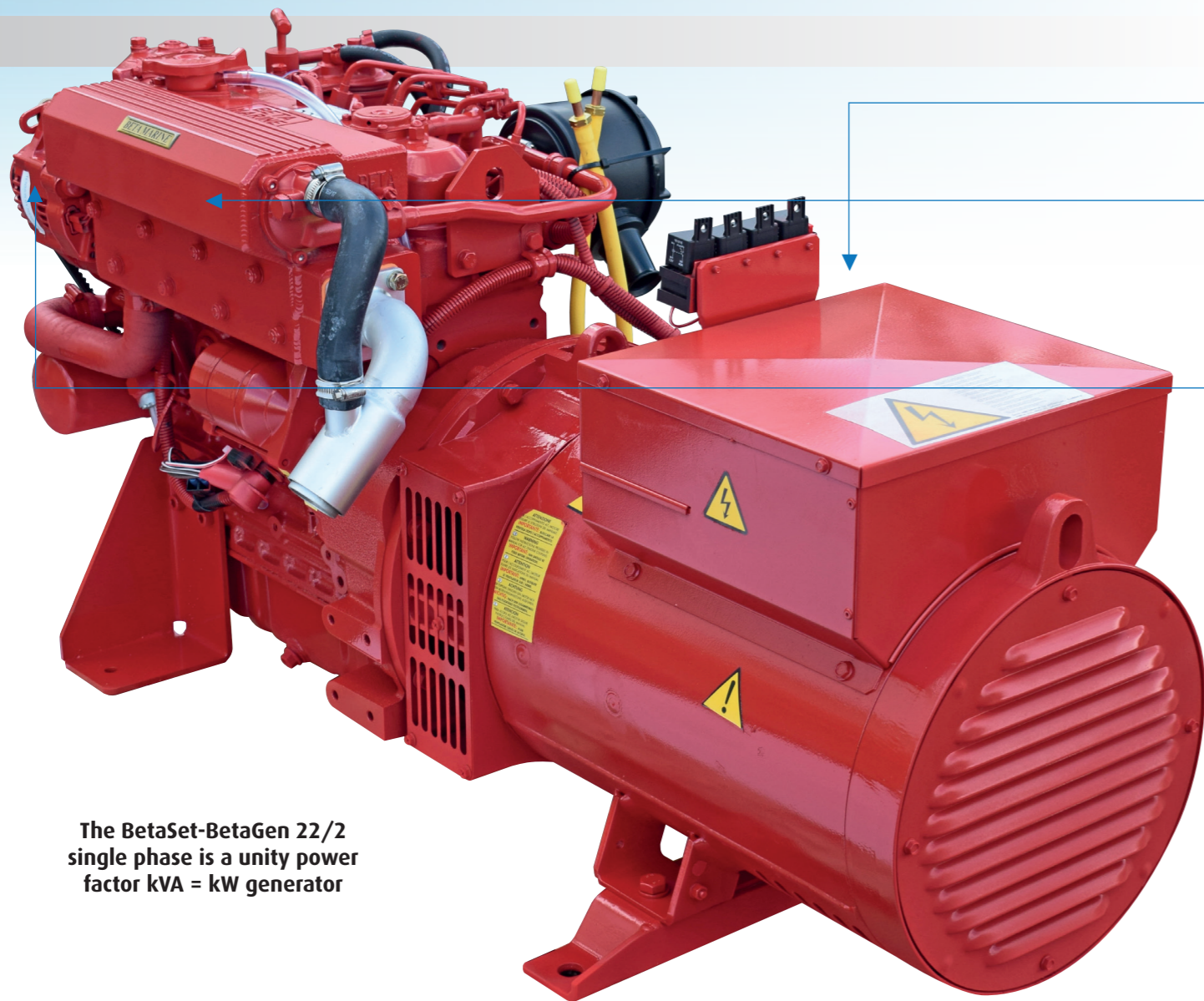

The BetaSet-BetaGen 22/2 single phase is a unity power factor kVA = kW generator

Cooling Options

Heat Exchanger Cooled	Std.	Radiator Cooled	Opt.
Keel Cooled	Std.		

Control Module Options

PSM720 Start & Stop Protection Module	Std.	DSE3110 Manual & Auto Start Control Module	Opt.
EPM72 Start & Stop Protection Module	Opt.*	DSE7310 Auto Start Control Module	
RSM72 Local & LPM72 Remote Control Module	Opt.	& DSE2510 Auto Start Display Module	Opt.

*Only when a 70 Amp, 12 Volt Insulated Return Alternator is specified.

Engine Electrical Options

45 Amp, 12 Volt Alternator	Std.	55 Amp, 24 Volt Electric Start & Alternator	Opt.
70 Amp, 12 Volt Insulated Return Alternator	Opt.		



BetaGen 22/2 Keel Cooled

Kubota Base Engine

	2-Pole AC Alternator	1 Phase, 50Hz 3,000 rpm	3 Phase, 50Hz 3,000 rpm 0.8PF	1 Phase, 60Hz 3,600 rpm	3 Phase, 60Hz 3,600 rpm 0.8PF
Max. Output		11.1 kVA	21.0 kVA	12.0 kVA	23.0 kVA
Typical Load		48.0 A*	23.0 A**	50.0 A***	24.0 A****
Cylinders		4	4	4	4
Cubic Capacity		1,498 cc	1,498 cc	1,498 cc	1,498 cc
Fuel[^]		4.5 Lt/Hr	4.5 Lt/Hr	4.8 Lt/Hr	4.8 Lt/Hr

BetaSet 22/2 Heat Exchanger Cooled

* Typical Maximum Amps at 230v based on kW Electrical Load.
 ** Typical Maximum Amps at 415v based on kW Electrical Load.
 *** Typical Maximum Amps at 240v based on kW Electrical Load.
 **** Typical Maximum Amps at 440v based on kW Electrical Load.
 ^ Approximate Fuel Consumption.
 All kVA continuous output ratings are Marine Class F temperature rises.

Dimensions & Weight

Images Below Are For Illustrating Dimensions & Not Necessarily Representative

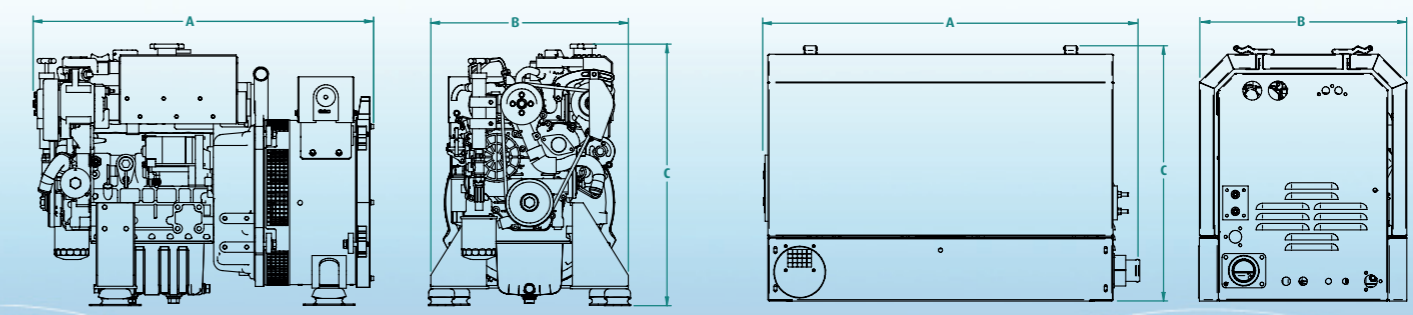

	A	B	C	Weight
BetaSet 22/2	116	51	62	286Kg
BetaGen 22/2	138	56	67	380Kg

These are typical dimensions: visit our website for all BetaSet-BetaGen option drawings or contact Beta Marine direct